

Renault-Nissan

ELECTRO-MOBILITY AND THE ELECTRICITY SECTOR: CHALLENGES AND SOLUTIONS



1. Electric vehicles - At the heart of the automotive transformation



ENERGY & ENVIRONMENTAL CHALLENGES



Resources
Reduce oil dependency



City & Health
“Airpocalypse”



Climate
Limiting warming < 2°C



TRANSPORT & SOCIETAL CHALLENGES



Mobility for all

Affordable mobility



Connectivity

Smart connections

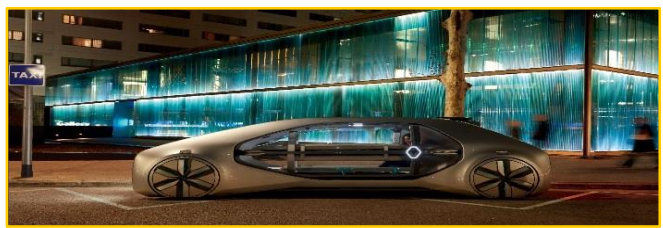

Innovation

Connected and Automated Driving

ANSWERING THE CURRENT AUTOMOTIVE TRANSFORMATION WITH ELECTRIC VEHICLES

1. Electric vehicles – At the heart of the automotive transformation

ENERGY & ENVIRONMENTAL CHALLENGES

- Resources**
Reduce oil dependency
- City & Health**
"Airpocalypse"
- Climate**
Limiting warming < 2°C

Confrontations Conference | RENAULT NISSAN | 07/06/2018 | 3

1. Electric vehicles – At the heart of the automotive transformation

TRANSPORT & SOCIETAL CHALLENGES

- Mobility for all**
Affordable mobility
- Connectivity**
Smart connections
- Innovation**
Connected and Automated Driving

Confrontations Conference | RENAULT NISSAN | 07/06/2018 | 4



Des ventes justifiées par l'attractivité des produits...

Less noise, less stress

- Low noise level
- Zero emission

RENAULT Z.E.

2. Promoting EV Development - One ambition, Many challenges



PROMOTING EV DEVELOPMENT

One ambition – Many challenges

1. Bring the customers on board by

- ✓ Managing the range level
- ✓ Speeding up EV cost reduction: Alliance platform & Battery cost breakthrough

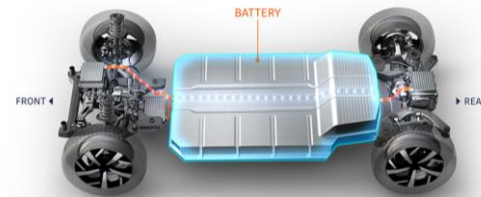

2. Make the EV a volume reality by

- ✓ An integrated approach with all stakeholders
- ✓ A sufficient deployment of charging and filling infrastructure
- ✓ A good level of incentives for the roll-out of ZEVs and PHEVs (smart pricing, subsidies)



THE AMBITION: DEPLOYMENT OF EV

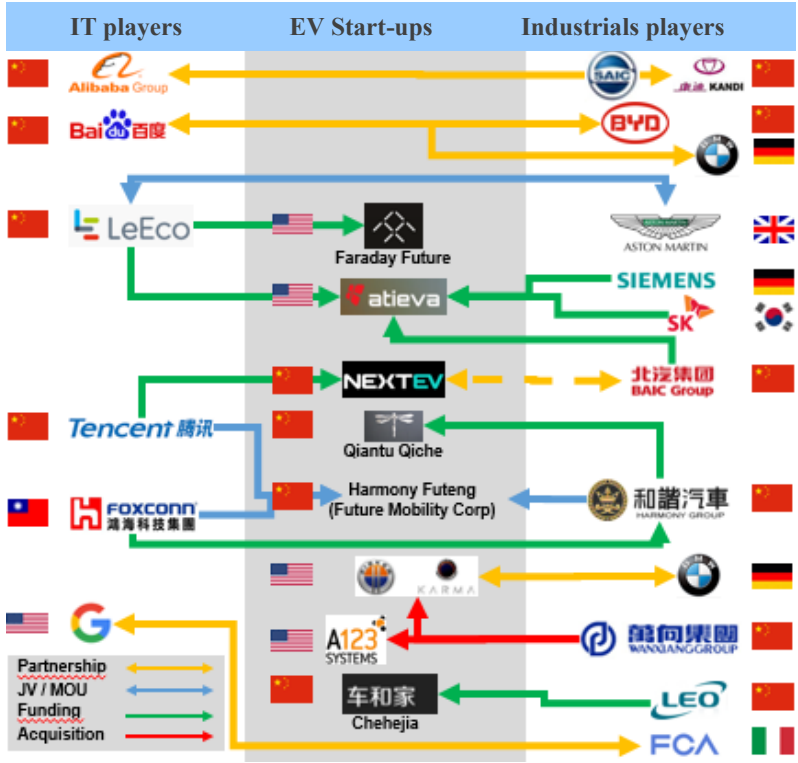
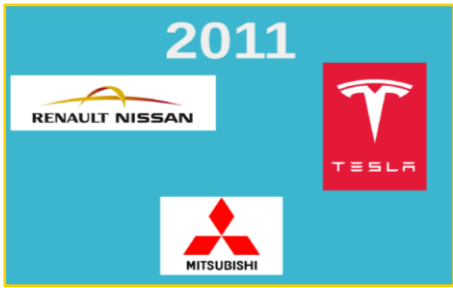

THE FACTS: LIMITED EV DEPLOYMENT

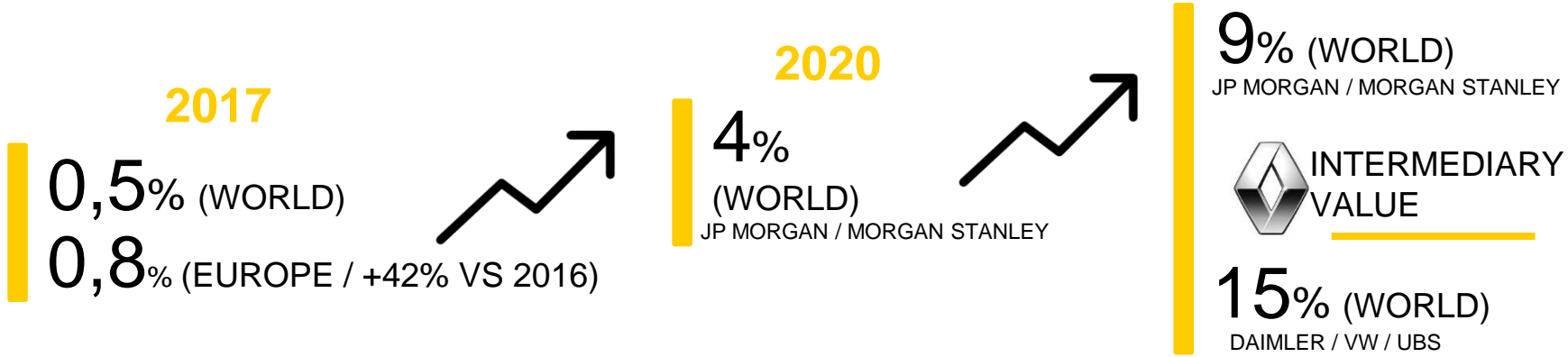

EXPECTATIONS

- ⚡ INCREASING NUMBER OF OEM/MODELS : **>50** GLOBAL BEV IN 2022
- ⚡ COST TIPPING POINT VE vs ICE : **2020-2025** DEPENDING ON SEGMENT & BATTERY SIZE
- ⚡ ALL SEGMENT COVERED BY 2021

3. Challenges and solutions to Electric Vehicles deployment



WHAT ARE THE SOLUTIONS?

Price / TCO

Enquete Satisfaction - 2015 G6

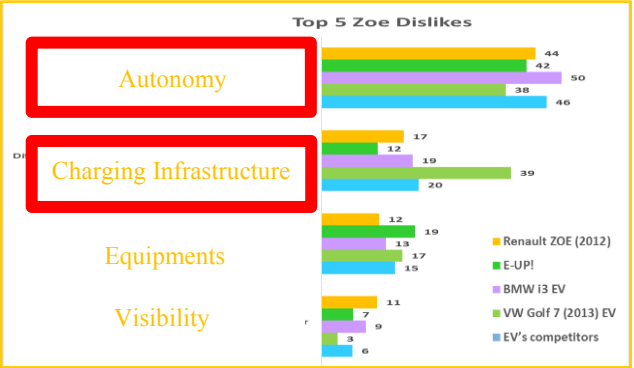

Autonomy

Infrastructure

WHAT ARE THE SOLUTIONS?

Enquete Satisfaction - 2015 G6

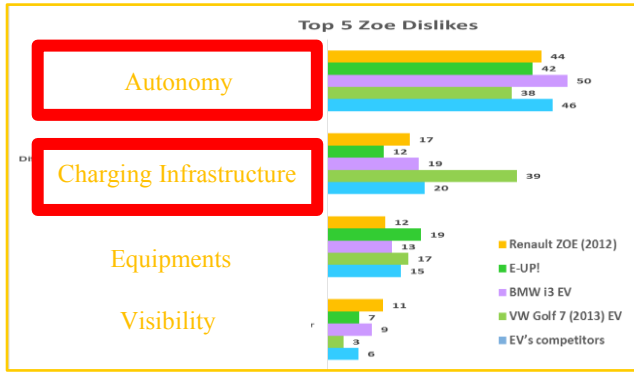

Price / TCO

Autonomy

Infrastructure

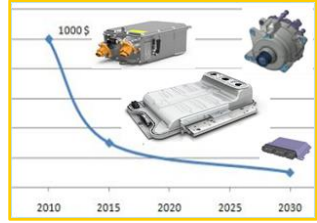

Technology evolution

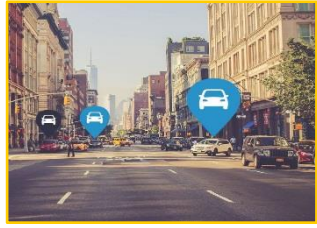

Public policies & Incentives

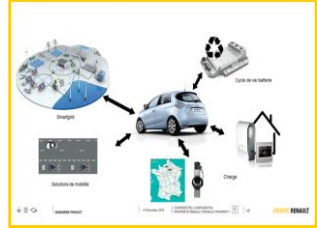

EV Ecosystem

3.1. Technology evolution



3.1. Technology evolution



Tomorrow, autonomy will not be a major issue anymore.



The charge operation will become :

- Easier
- Faster
- More accessible

3.1. Technology evolution

EV RANGE FORECAST

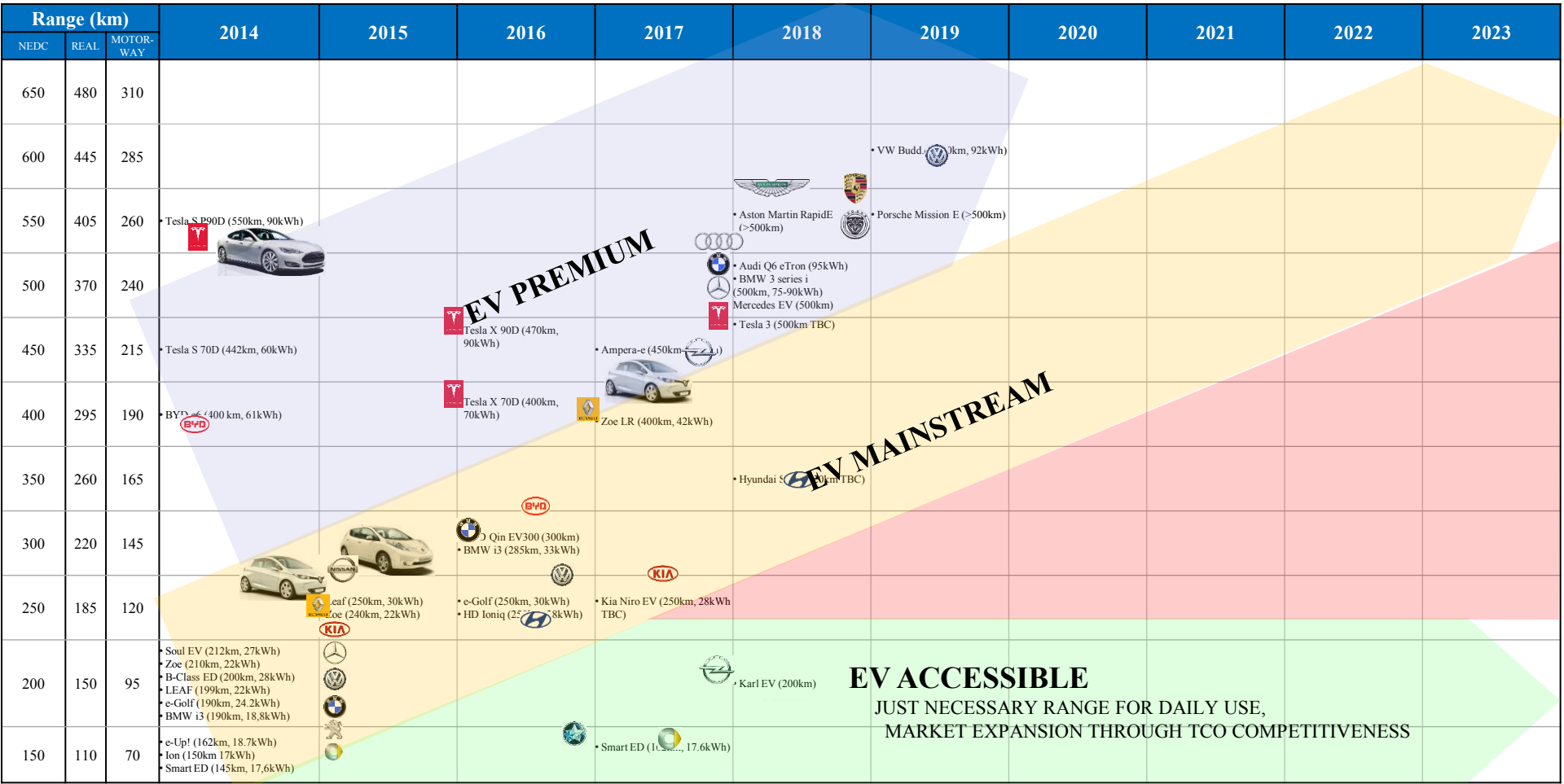

EV PREMIUM

EV MAINSTREAM

EV ACCESSIBLE
 JUST NECESSARY RANGE FOR DAILY USE,
 MARKET EXPANSION THROUGH TCO COMPETITIVENESS

ON-BOARD & OFF-BOARD CHARGE

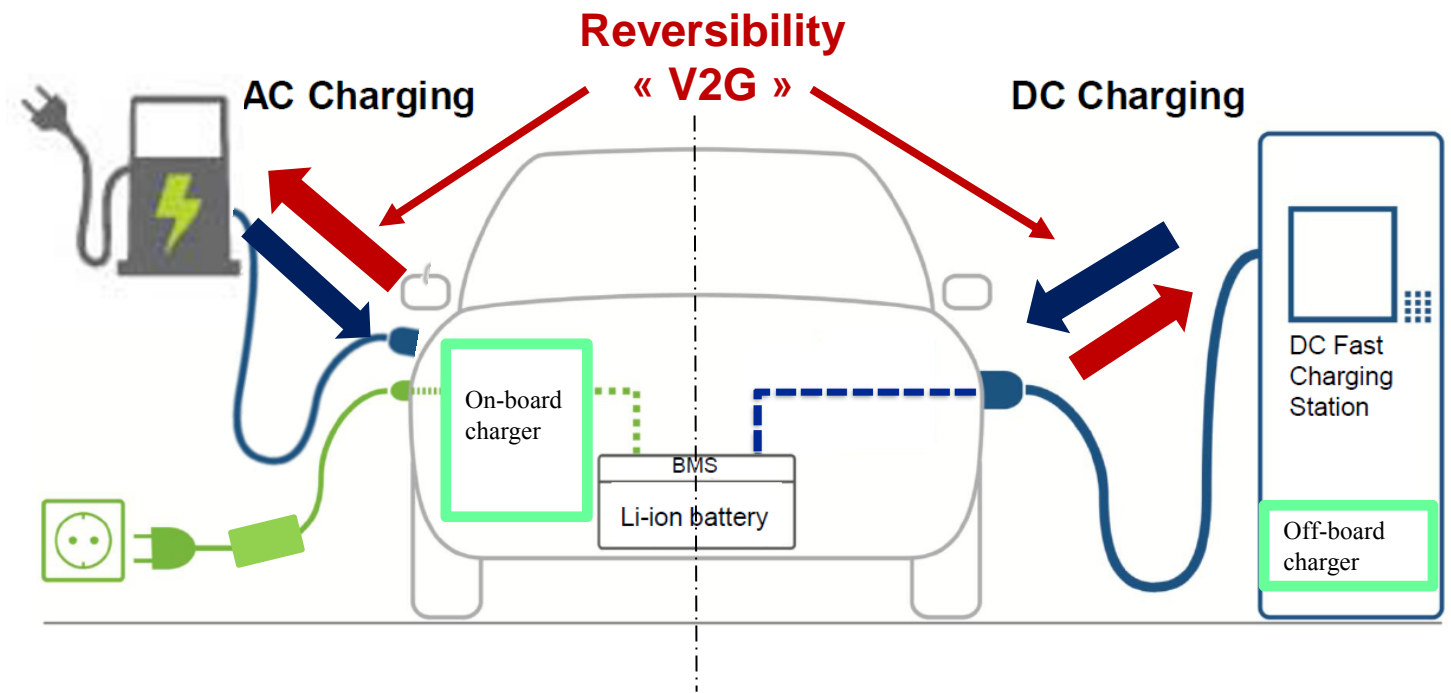

3.2. Public policies & incentives



NEED FOR STRONG INCENTIVES SUPPORT



Investment in infrastructures



Parking access



Free parking



Fiscal incentives



Priority lanes



No traffic restrictions

3.3. Alliance Strategy - Building an Eco-system for Electric Vehicles



AN ECOSYSTEM SPECIFIC TO ELECTRIC VEHICLES

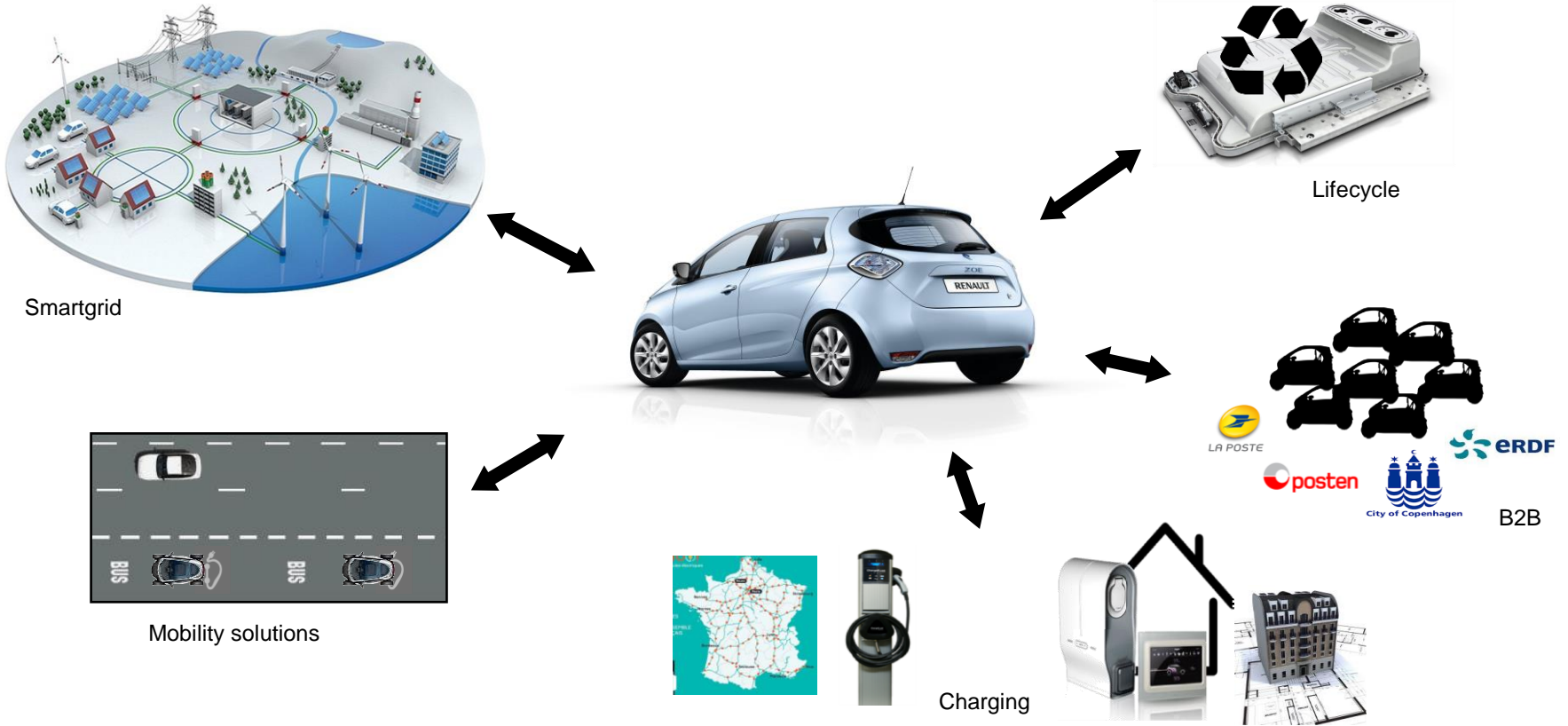

AN ECOSYSTEM SPECIFIC TO EV BASED ON PARTNERSHIPS

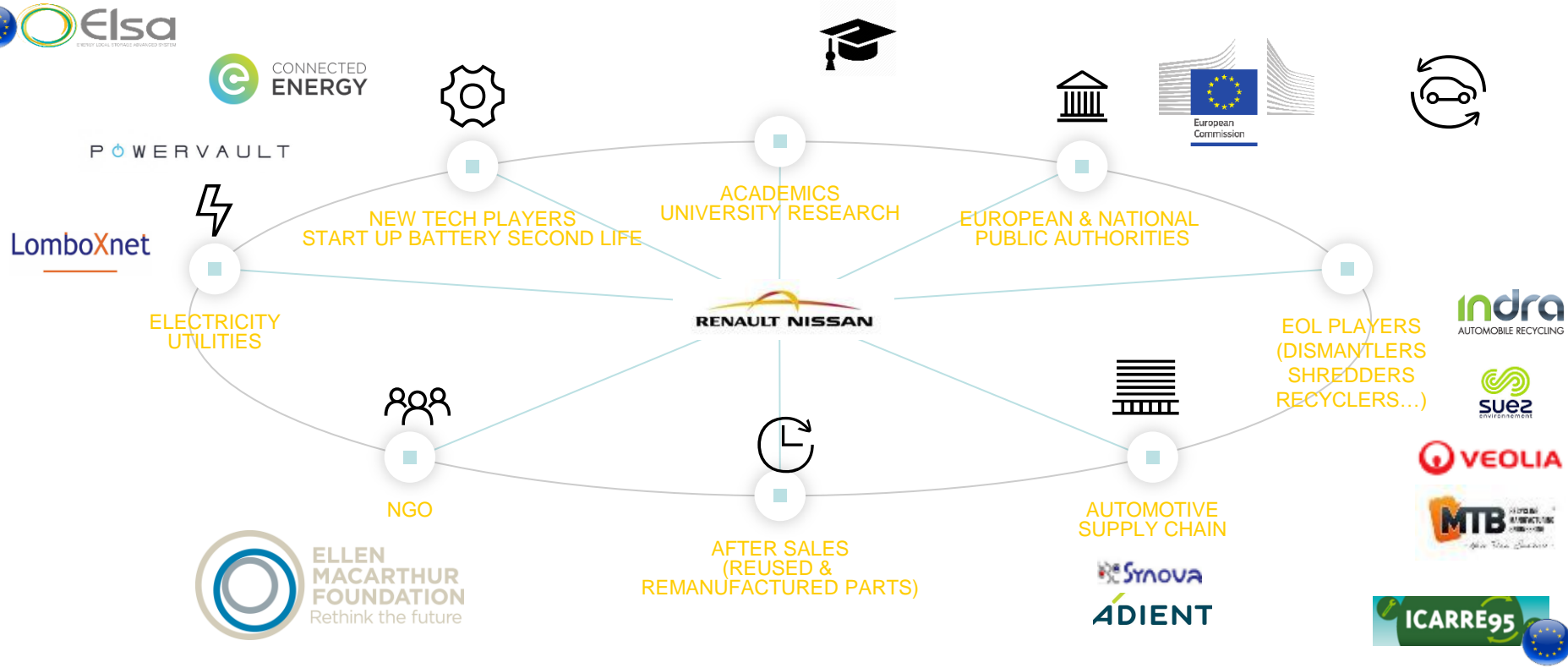

AN ECOSYSTEM SPECIFIC TO ELECTRIC VEHICLES



DEVELOPPING NEW SERVICES FOCUSSSED ON CONSUMERS' NEEDS

Renault Energy Services



FAST CHARGING

E.g. E-STOR: Fast charging stations with second-life batteries from Renault's EV

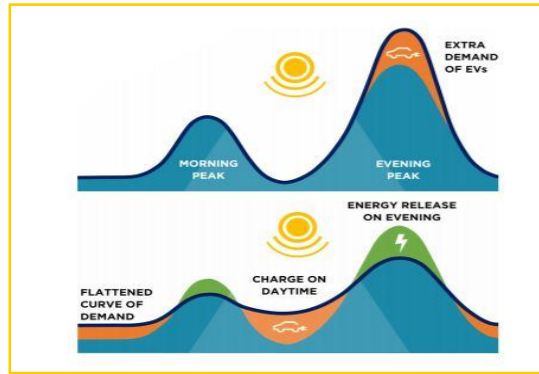

SMART CHARGING

E.g. Pilot home charging to match electricity operators needs 25% stake in JEDLIX



E.g. Launch of Renault Z.E. Smart Charge Apps.



SECTOR COUPLING

Connect clean energy to grid and buildings

INITIATIVES TO ACCELERATE THE DEPLOYMENT OF CHARGING INFRASTRUCTURES



EV READY – CERTIFICATION LABEL, LEAD BY RENAULT

- Charging spots conformity, and their installation
- Third party certification ASEFA (LCIE BV)
- Includes Renault, PSA, Nissan, Mitsubishi + ad-hoc participation VW, DAI, Toyota, Ford...



GIREVE – THE RENAULT SOLUTION FOR INTEROPERABILITY

- SAS Renault, EDF, ENEDIS, Caisse des dépôts, CNR created in 2013
- Insure services interoperability of EV charging in Europe
- Major PF interconnexion through Pan-European Initiative (2014)



E-VIA FLEX-E – PARTNERSHIP FOR FAST CHARGING STATIONS

- 14 Fast charging stations (between 150 kW and 350 kW) in Italy, France and Spain
- ENEL, Nissan, EDF, Enedis, Verbund and IBIL

AN ECOSYSTEM SPECIFIC TO ELECTRIC VEHICLES

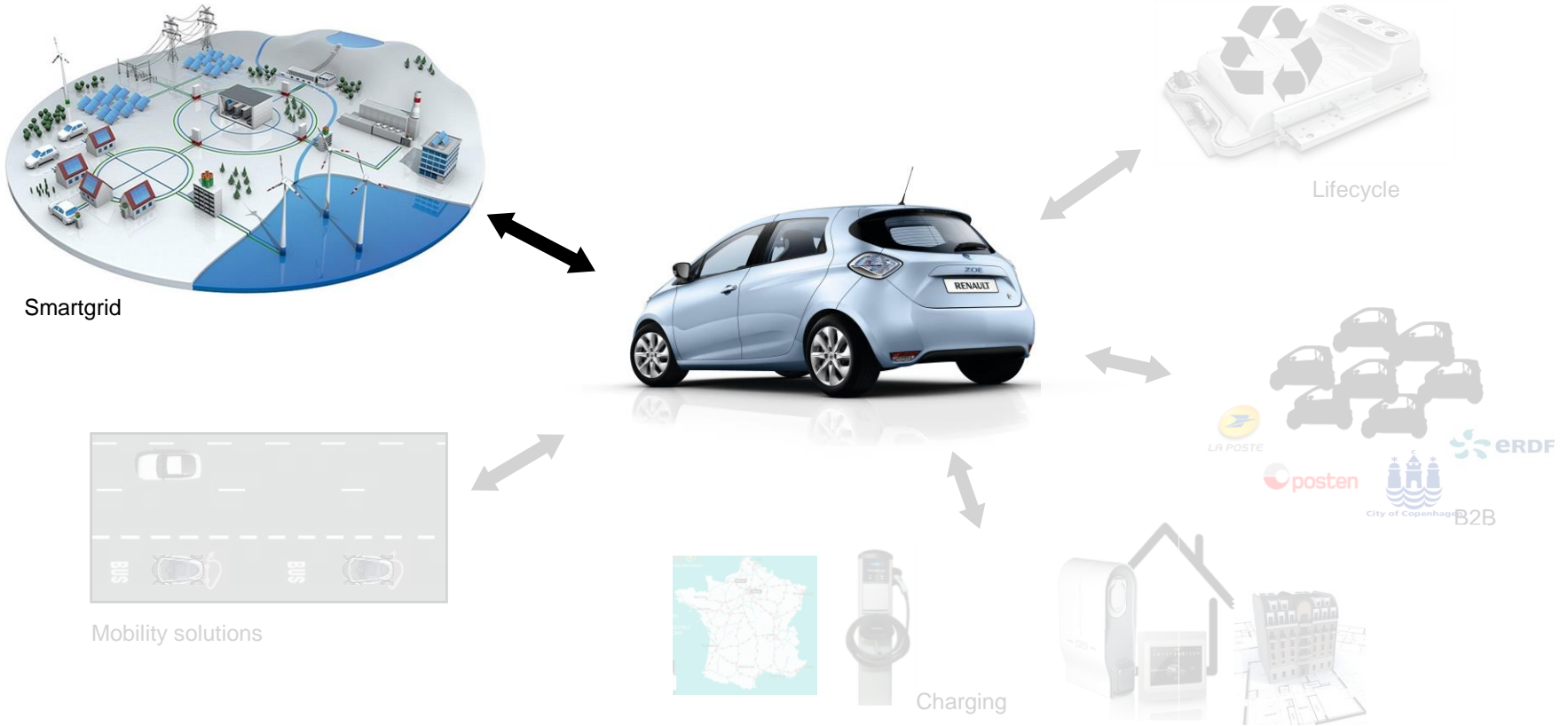

A TRANSFORMATION ALSO FOR ENERGY

COP21: MOVING TO RENEWABLES

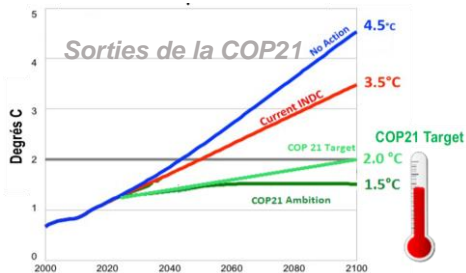

Domaine	Contribution
Agriculture	0%
Services	2%
Résidentiel	3%
Transports	19%
Industrie	15%
Autres	9%
Energie	52%

2050 contribution to reach +2°C (IEA)

- Worldwide acceleration of RNW
- COP21: more than 50% contribution in Energy

A NEED FOR FLEXIBILITY IN RENEWABLES

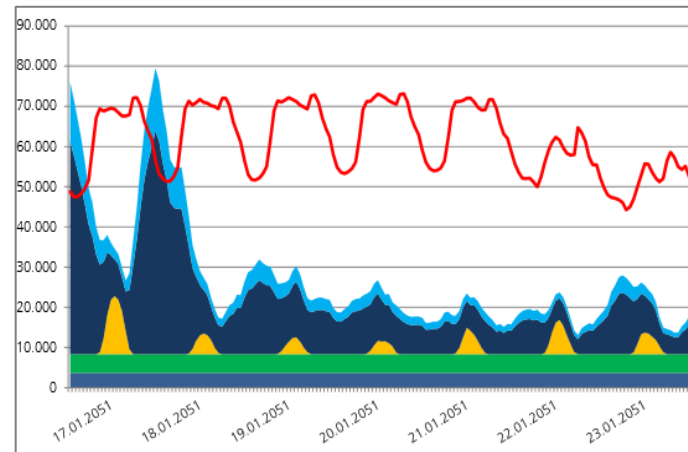

Hydropower, Biomass, PV, Wind Offshore, Wind Onshore, Electricity Consump.

- Cyclic and irregular consumption
- Intermittent and distributed RNW production

THE ELECTRIC VEHICLE, A KEY PLAYER OF SMART ENERGY

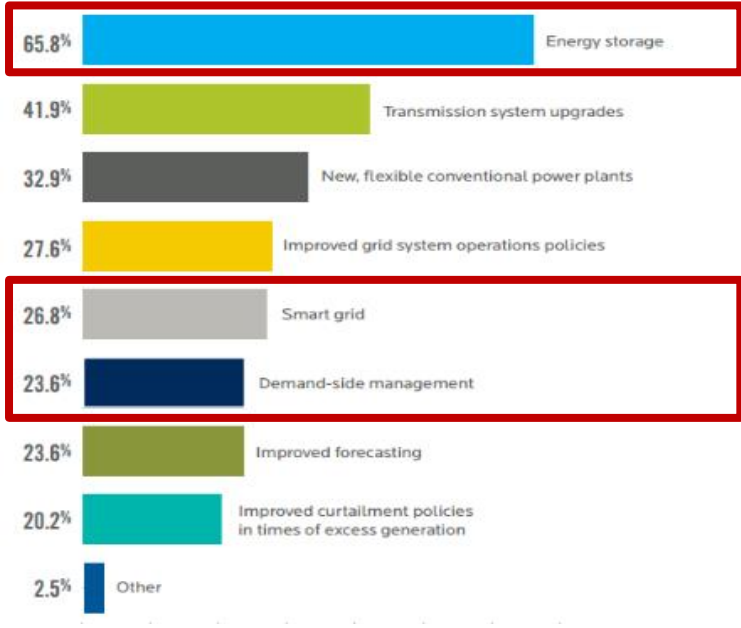

Enabling Technologies towards Renewable Energies

THE ELECTRIC VEHICLE, A KEY PLAYER OF SMART ENERGY

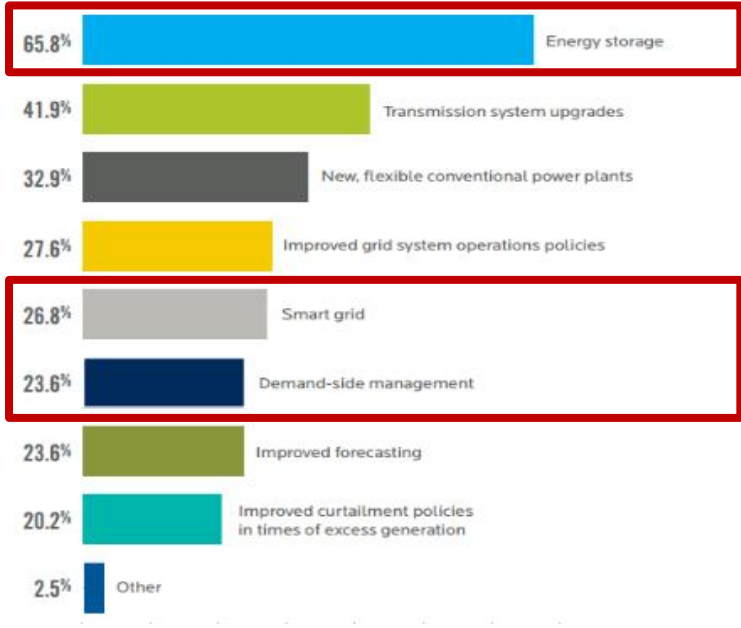

Smartcharging:
EV, a controllable consumer !
even an electricity producer !!



Energy Storage:
Second life EV batteries

Enabling Technologies towards Renewable Energies

SEVERAL SERVICES CAN BE PROVIDED BY EV



To optimize energy consumption



Price
→ €

Quantity
→ kWh

CO2,
Green En.



To optimize power



Subscription



Grid connection



Peak Power



To help network stability



Frequency



Voltage



Quality

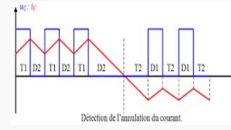

Special features



Islanding

Véhicule Rescue
V2V

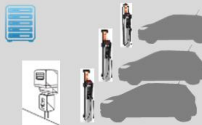

Fleet Management

THE ELECTRIC VEHICLE, A KEY PLAYER OF SMART ENERGY

A huge potential in a 2025 market projection of several millions of vehicles

Alliance Renault/ Nissan today



400 000 Electric Vehicles
sold by Renault / Nissan



11 gas plants
(2300 wind turbines)



10 days of Paris public
infrastructures consumption

AN ECOSYSTEM SPECIFIC TO ELECTRIC VEHICLES



WHY USING SECOND LIFE BATTERIES ?

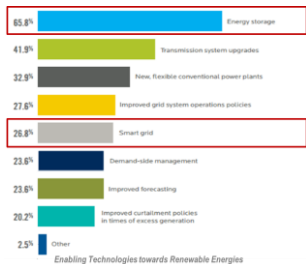

- High safety level
- Technical performance
- Towards a mass market
- Affordable: << new battery price

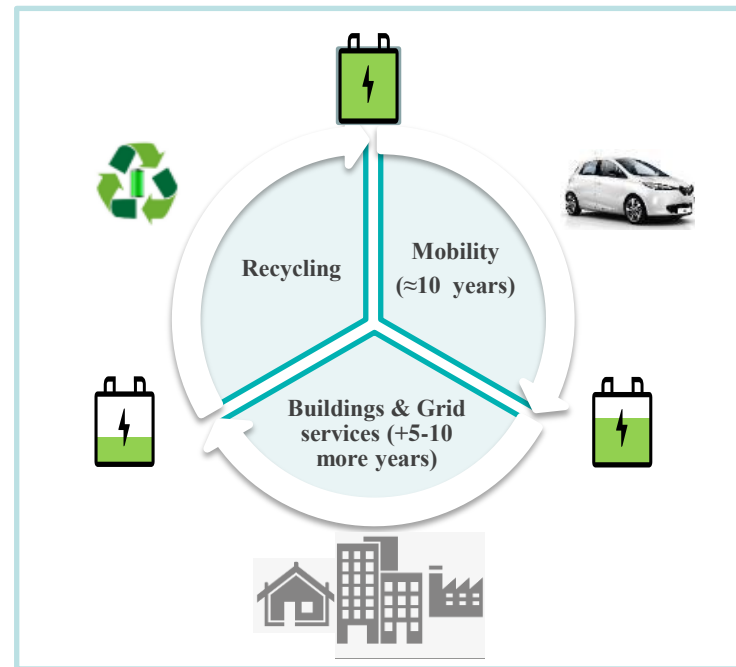

ELSA project

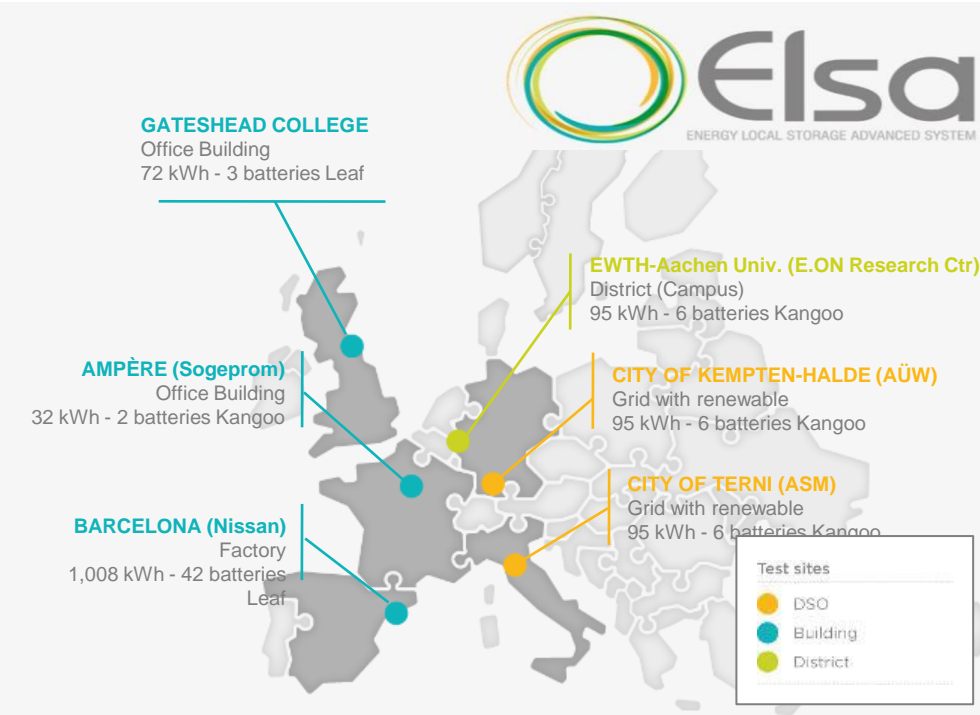

6 pilot sites to cover all important use cases for **small and medium storage solutions**



AN ECOSYSTEM SPECIFIC TO ELECTRIC VEHICLES

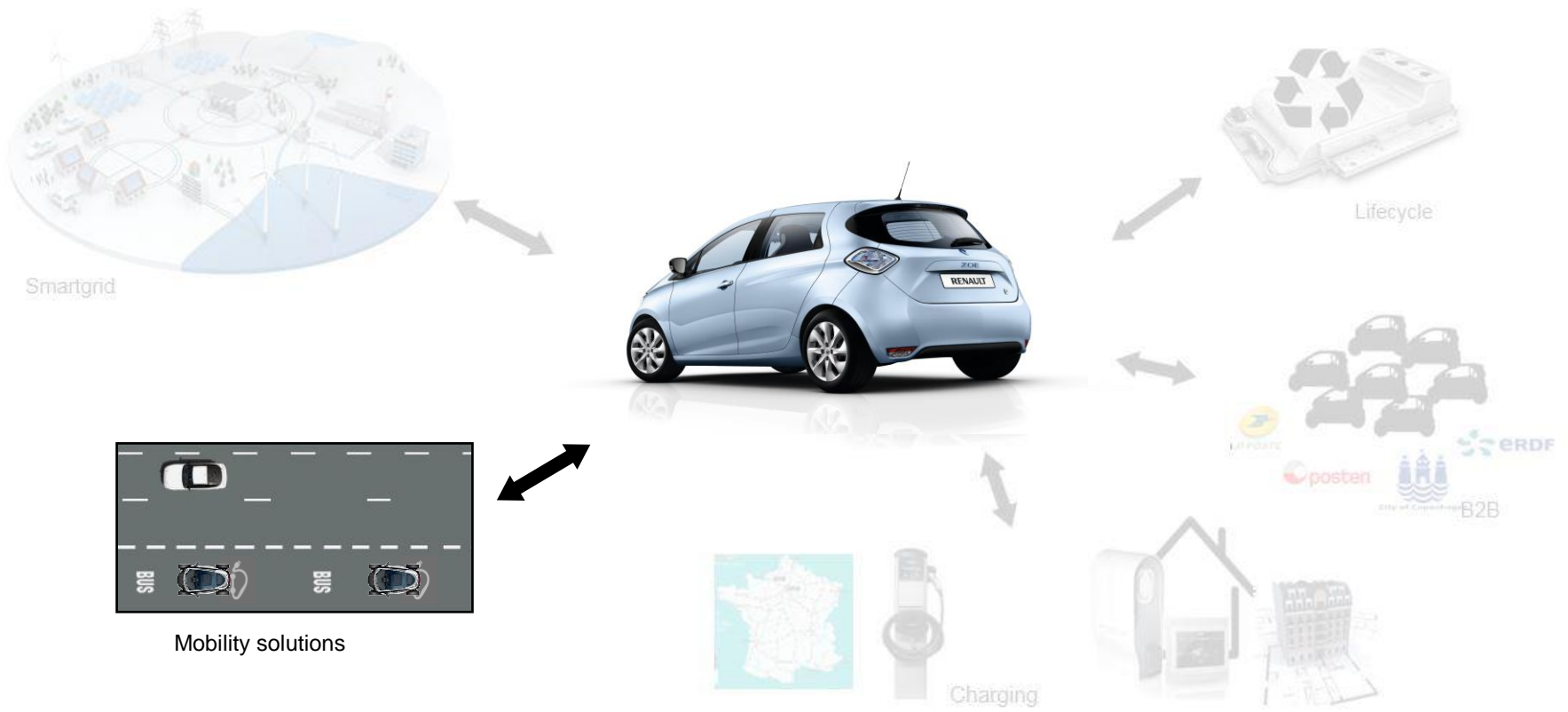

DEVELOPPING NEW MOBILITY SOLUTIONS TO ANSWER TO CONSUMERS' NEEDS



Example:
Carsharing



Engage in main cities car-sharing projects

E.g. 500 ZOE with Ferrovial in Madrid

Engage in partnerships

E.g. Renault Mobility & IKEA:
300 vehicles, 100% electric

3
6

THANK YOU

